

A ONE-KILOWATT AMPLIFIER USING A 3-500Z

Circuit design for high-power linear amplifiers hasn't changed much in recent years. The differences between various types of grounded-grid units are usually more mechanical than electrical. The degree of circuit complexity is determined primarily by the number of features desired and if the power supply and control circuits are included on the same chassis as the amplifier. Described below is a power amplifier designed to operate break-in cw as the primary mode. A suitable exciter is described earlier in the chapter. Other equipment combinations were shown in *QST* for December 1971.

The Power Supply

A voltage-doubler circuit connected to the secondary of T1 provides approximately 2600 volts dc. See Fig. 1. The primary of T1 can be operated from either a 117-volt line or a 220-volt source; the latter voltage is preferred. U1 and U2 are suppressors included to prevent transients from damaging the high-voltage capacitor bank or the rectifier diodes. Since T1 has two 117-volt primary windings, a suppressor is connected across each. The windings and suppressors are connected in parallel for 117-volt operation, and they are series connected for a 220-volt line.

A relay (K1) is necessary to switch the high-current inrush when the supply is activated. Ordinary toggle switches cannot be used to activate the power supply directly. Surge protection is accomplished by placing R1 in series with one lead of the ac line. K3B shorts out this resistor a few seconds after the main power switch (S1) is

actuated. A separate line cord for the power supply allows this section to be operated on 220 volts while permitting other circuits in the amplifier to operate on 117 volts.

The Amplifier Circuit

A single 3-500Z triode tube develops 1-kW input on cw and 1-kW PEP on ssb. The output circuit is a conventional pi network which tunes the hf amateur bands from 3.5 to 30 MHz. The T-R switch, similar to the one used in the T-9er, is coupled to the tank circuit via C1. This capacitor is constructed of RG-8A/U and is 3 inches long.

Filament voltage is applied to the 3-500Z through a bifilar-wound rf choke. Drive power is coupled to the filament circuit via C2, a disk-ceramic capacitor.

Two Zener diodes are used to develop grid bias. S3C selects either CR18 for 27 volts (cw) or CR19 for a 7.5-volt bias (ssb). Since the lower bias voltage increases the standing plate current to approximately 80 mA, R7 is placed in series with the cathode-return lead to cut off the tube during standby periods. Protection for the power supply is assured by placing a 1-ampere fuse in series with the Zener diodes. This procedure could save a tube or a meter (not to mention power supply components!) in the event a high current surge or arc occurs in the output circuit.

The Multimeter

A 1-mA meter is used to measure grid current, plate voltage, and power output. R4, mounted on the rear chassis apron, allows adjustment of the

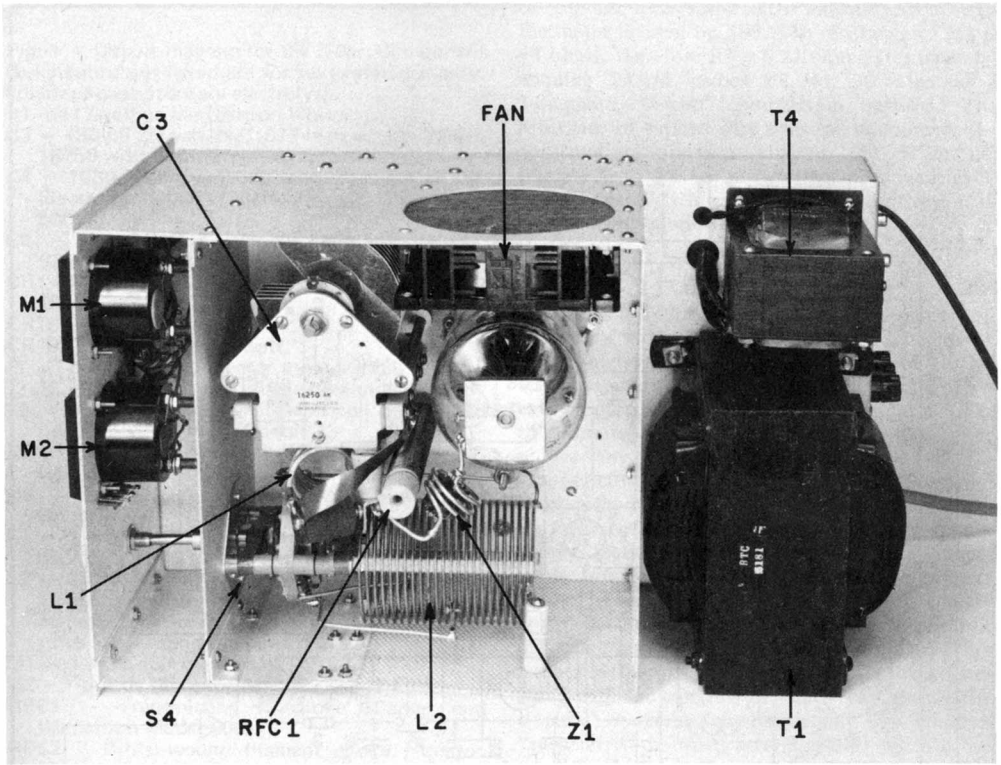

Top view.

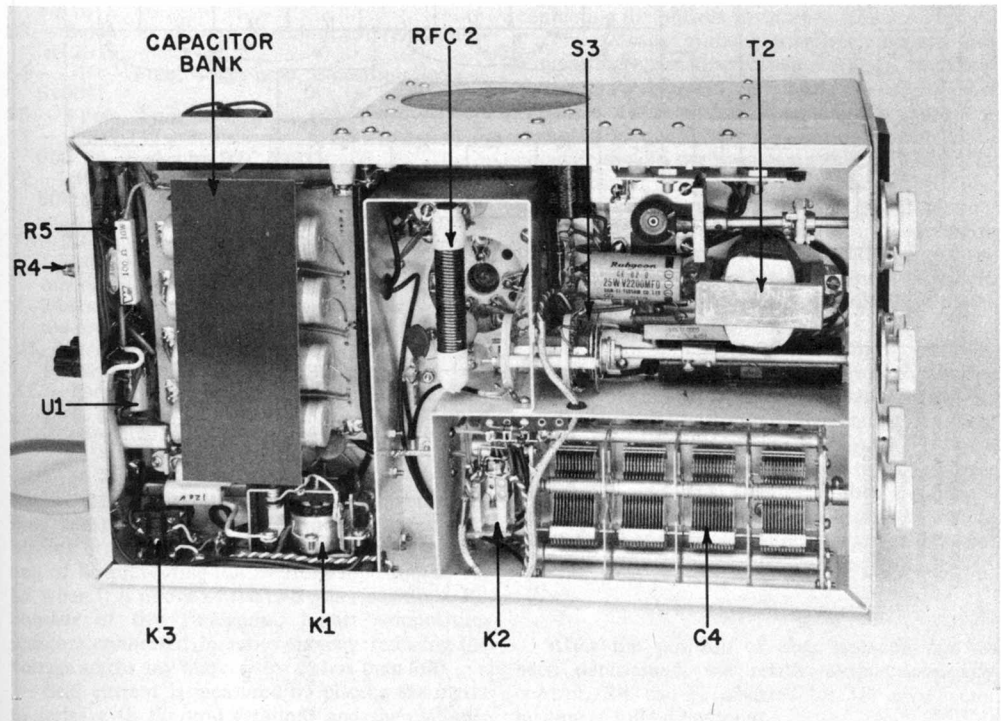

Bottom view.

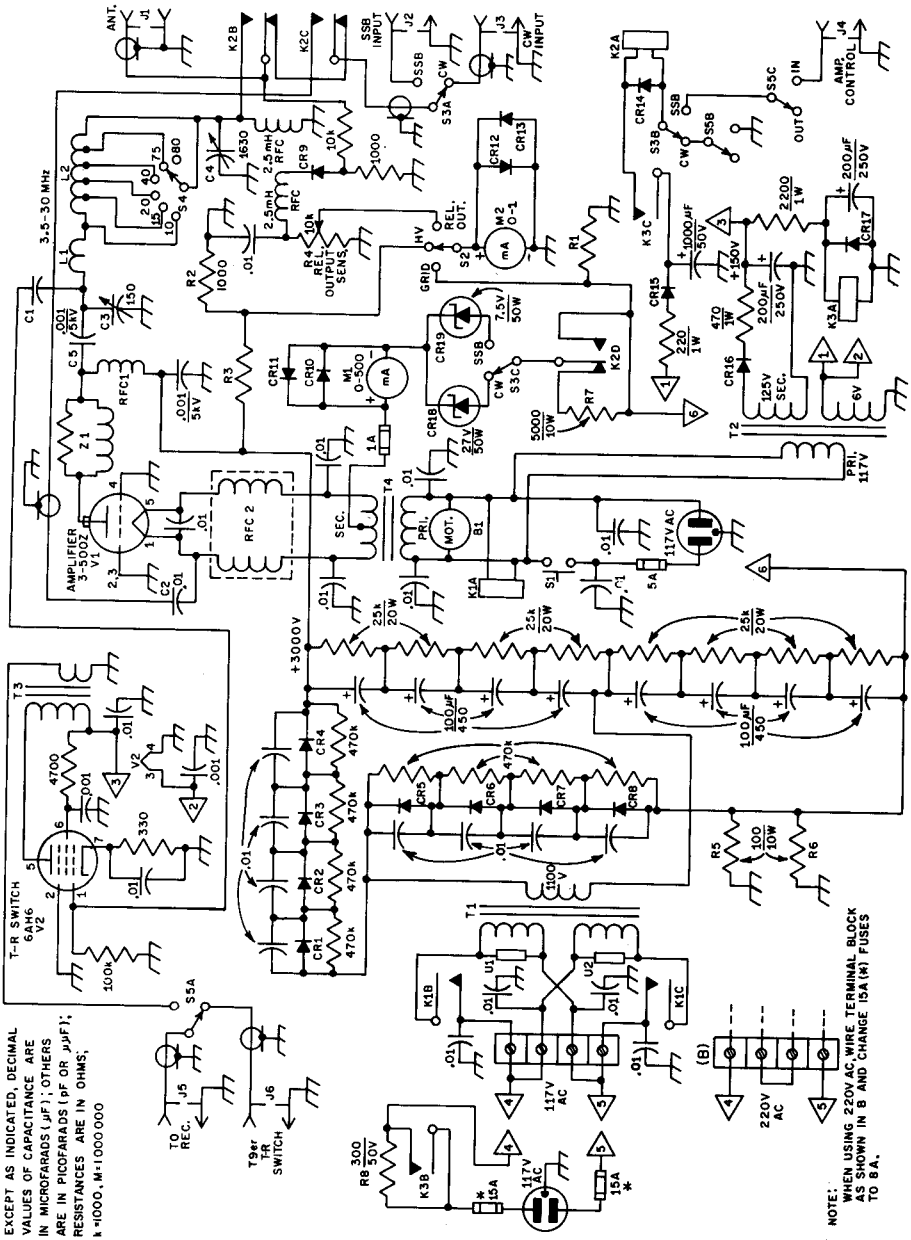

EXCEPT AS INDICATED, DECIMAL VALUES OF CAPACITANCE ARE IN MICROFARADS (μF); OTHERS ARE IN PICOFARADS (PF OR μμF); RESISTANCES ARE IN OHMS; 1 = 1000, M = 1000,000

NOTE: WHEN USING 220V AC WIRE TERMINAL BLOCK AS SHOWN IN B AND CHANGE 15A (M) FUSES TO 8A.

Fig. 1 — Circuit diagram for the S-9er. Component designations not listed are for text reference only. Polarized capacitors are electrolytic.

- B1 — 117-volt ac fan (Rotron Whisper).
 C3 — 180-pF air variable, .077-inch air gap (Millen 16250 with 4 stator plates removed).
 C4 — 1680-pF air variable, receiving type (R. W. Electronics, 4005 W. Belmont Ave., Chicago, IL 60641).
 C5 — Transmitting capacitor, 1000-pF ceramic (Centralab 858S-1000).
 CR1-CR17, incl. — 1000-PRV, 2.5-A (Mallory M2.5A or equiv.).
 CR18 — Zener, 7.5-V, 50-watt.
 CR19 — Zener, 27-V, 50-watt.
 J1 — Coax chassis connector, type SO-239.
 J2-J6, incl. — Phono jack, single-hole mount.
 K1 — Power relay, dpdt, 117-volt coil (Potter and Brumfield PR-11AY or equiv.).
 K2 — 4pdt, 5-A, 6-V dc coil (Potter and Brumfield GPD coil and GO-17 contact arrangement).
 K3 — Dpdt, 10-A, 120-V dc coil (Potter and Brumfield KA11DG or equiv.).
 L1 — 7 turns, 1/8-inch copper tubing, 1 1/4-inch dia, tapped at 3 turns from tube end.
 L2 — 23 turns, No. 14, 2 1/2-inch dia, tapped at 10 3/4 turns for 40 meters, 17 1/2 turns for 20 meters, as measured from the C4 end. (Coil stock: Barker and Williamson 3029.)
 M1 — 1-A dc (Simpson Model 2122-17400).
 M2 — 1-mA dc (Simpson Model 2122-17430).
 RFC1 — Transmitting rf choke (Barker and Williamson Model 800).
 RFC2 — Bifilar-wound filament choke (Amidon 10-A choke kit or equiv.).
 S1 — Spst push button (Calectro E2-144).
 S2 — Single-pole, 3-position rotary (Calectro E2-161).
 S3 — 3-pole, 2-position, 2-section, rotary (Centralab 2515).
 S4 — Rf switch, single-pole, 6-position (Millen 51001).
 S5 — 3-pole, 2-position, rotary (Calectro E2-165).
 T1 — Dual 117-volt primary, 1100-V secondary, 600 VA (Berkshire BTC 6181).
 T2 — 117-volt primary; secondary 125 volts at 50-mA; 6.3-V at 2-A (Stancor PA-8421 or equiv.).
 T3 — 20 turns, No. 24 enameled wire wound on a 1-inch long, 1/2 inch dia iron core from a slug-tuned coil form. The secondary is 3 turns No. 24 enameled wire wound over the cold end of the primary.
 U1, U2 — Transient voltage suppressor, 120-volt (General Electric 6RS20SP4B4).
 Z1 — Parasitic suppressor, 3 turns No. 12 copper wire, 1 1/4-inch dia wound over three 150-ohm, 2-watt composition resistors.

relative-output circuit sensitivity. A voltage-dropping resistor network, R3, provides a full-scale reading of 5 kV. R2 maintains a load at the meter end of R3 preventing full B+ from appearing across S2 when it is in one of the two other positions. R3 consists of five 1-megohm, 1-watt composition resistors connected in series thereby reducing the voltage across any one resistor to less than 600.

Grid current is measured by placing the meter in series with the grid (ground) and the cathode. The meter shunt, R1, provides a full-scale reading

of 500 mA. R1 is equal to the internal resistance of the meter divided by 500. The resistance of M1 is 43 ohms; therefore R1 is 0.21 ohm. It is made by winding 24 1/4 inches of No. 30 wire on a 1-megohm, 2-watt composition resistor. The resistance of various wire sizes can be found in the construction practices chapter. R1 is in the primary path for the high-voltage negative lead to chassis ground. R5 and R6 provide protection in the event this meter shunt opens.

Construction

The amplifier, including the power supply, is built on a 10 X 17 X 3-inch aluminum chassis. All of the high-voltage power supply components are mounted at the rear of the chassis. Location of the various parts is shown in the photographs. All of the circuits carrying rf are completely shielded to reduce any instability or TVI generation. The input-circuit shield is mounted between S3 wafers to keep the rf wiring inside the compartment.

Extreme care must be taken in the power supply section to keep the high-voltage components from coming in contact with the primary wiring. This section of the amplifier is very crowded. A sheet of 1/16-inch thick phenolic insulating material is placed between the capacitor bank and the chassis. The electrolytic capacitors, along with the equalizing resistors, are mounted on a piece of etched circuit board. This board is "suspended" between several solder lugs attached to ceramic standoff insulators. Rubber cement is used to hold a 1/2-inch thick piece of phenolic board to the capacitors to prevent them from contacting the bottom plate when it is installed.

The rf-output circuit is completely shielded in a compartment constructed of cane metal and sheet aluminum. Perforated material is needed to allow adequate air flow past the tube. The socket is mounted 1/2 inch above the chassis, allowing air to circulate around the base connections and seal. The grid pins of the socket are soldered to lugs mounted on the chassis.

When a standard Eimac plate cap is used with the 3-500Z, the cap extends above the edge of the cabinet. Therefore, a 1/4-inch thick aluminum plate, 1 3/4-inches square, is used in place of the Eimac unit.

The plate-tuning capacitor, C3, is vertically mounted and is adjusted from the front panel using a surplus right-angle drive. A Millen drive works equally well. C4 has a shaft diameter of 3/8 inch, requiring special attention. A standard 1/4-inch coupling with one end drilled out to slightly over 3/8 inch is used as an adapter. Fine-mesh screen is placed between the cabinet wall and the fan to maintain an rf-tight enclosure. The screen does not appear to reduce the air flow appreciably.

Operation

After the position of each tank-coil tap has been determined, the relative-output sensitivity control, R4, can be adjusted for 3/4 scale meter reading at full power input.

In order to determine the plate current, the grid

current must be subtracted from the cathode current. When the amplifier is driven to a grid current of 120 mA and the tuning controls are adjusted for maximum power output, the cathode current will be about 500 mA and the plate voltage will be slightly over 2500. This represents an input power of approximately 950 watts. After extended periods of operating or tuning, the fan should be left on for a few minutes to allow the tube to cool.

Fig. 1 shows several methods for interconnecting the station equipment. The exciter IN/OUT function is performed by S5B which deenergizes K2 to allow the exciter to feed through to the antenna. The appropriate T-R switch output is routed to the receiver by S5A. *Caution:* When S3 is in the cw position, there is no load connected to the ssb exciter input terminal. Likewise, there is no load on the cw input connector when S3 is in the ssb position.